



.....
Elite Disc Drive

.....
ST43401N/ND

.....
ST43402ND

.....
Reference Manual

Contents

| | |
|--|-----|
| Preface | iii |
| Electrostatic discharge protection | iii |
| Important safety information and precautions | iv |
| Technical support services | vi |
| Section 1. General maintenance information | 1 |
| Section 2. Planning the system | 5 |
| Section 3. Interface functions | 19 |

© 1994 Seagate Technology, Inc. All rights reserved
Publication number: 83327730, Rev. C
December 1994

Seagate®, Seagate Technology®, and the Seagate logo are registered trademarks of Seagate Technology, Inc. Elite™, SeaFAX™, SeaFONE™, SeaTDD™, and SeaBOARD™ are trademarks of Seagate Technology, Inc. Other product names are registered trademarks or trademarks of their owners.

Seagate reserves the right to change, without notice, product offerings or specifications. No part of this publication may be reproduced in any form without written permission from Seagate Technology, Inc.

Preface

This is a reference manual for users of Seagate® ST43401N/ND and ST43402ND Elite™ disc drives employing the SCSI interface. It supplements the information presented in the user's manual (publication 83327720). It is intended to aid engineers who design subsystems using the drive and customer engineers who install and check out the drive. This manual should be used in conjunction with the user's manual.

Electrostatic discharge protection

Caution. Removal of circuit boards by personnel not performing depot repair will damage components and may void the warranty.

All drive electronic assemblies are sensitive to static electricity due to the electrostatically sensitive devices used within the drive circuitry. Although some devices such as metal-oxide semiconductors are extremely sensitive, all semiconductors, as well as some resistors and capacitors, may be damaged or degraded by exposure to static electricity.

Electrostatic damage to electronic devices may be caused by the direct discharge of a charged conductor, or by exposure to the static fields surrounding charged objects. To avoid damaging drive electronic assemblies, service personnel must observe the following precautions when servicing the drive:

- Ground yourself to the drive whenever the drive electronics are or will be exposed. Connect yourself to ground with a wrist strap (Seagate part number 12263496). Connection may be made to any grounded metal assembly. As a general rule, remember that you and the drive electronics must all be grounded to avoid potentially damaging static discharges.
- Turn off power before removing or installing the DC power cable.
- Do not remove any circuit boards from the drive.
- Never use an ohmmeter on any circuit boards.

Important safety information and precautions

Caution. Use forced-air ventilation when bench-testing the drive to ensure proper cooling of drive components.

Use proper safety and repair techniques for safe, reliable operation of this unit. Service should be done only by qualified persons. We recommend the procedures in this manual as effective ways of servicing the unit. Some procedures require the use of special tools. For proper maintenance and safety, you must use these tools as recommended.

The procedures in this manual contain warnings and cautions that must be carefully read and followed to minimize or eliminate the risk of personal injury. The warnings point out conditions or practices that may endanger you or others. The cautions point out conditions or practices that may damage the unit, possibly making it unsafe for use.

You must also understand that these warnings and cautions are not exhaustive. We cannot possibly know, evaluate, and advise you of all the ways in which maintenance might be performed or the possible risk of each technique. Consequently, we have not completed any such broad evaluation. If you use a non-approved procedure or tool, first ensure that the method you choose will not risk either your safety or unit performance.

Always observe the following warnings and precautions:

- Perform all maintenance by following the procedures in this manual.
- Follow all cautions and warnings in the procedures.
- Use sound safety practices when operating or repairing the unit.
- Use caution when troubleshooting a unit that has voltages present. Remove power from the unit before servicing it.
- Wear safety shoes when removing or replacing heavy parts.
- Ensure that the internal temperature of the rack or cabinet will not exceed the limits defined for the drive when the drive is mounted in an equipment rack or cabinet. When units are stacked vertically, pay special attention to the top where temperatures are usually highest.
- Follow the precautions listed under “Electrostatic discharge protection” above.

- Do not remove any circuit boards from the drive chassis. Return the entire drive for depot repair if any circuit board is defective. Removal of circuit boards by personnel not performing depot repair will damage components and may void the warranty.
- Do not remove the head and disc assembly (HDA) from the drive chassis. Return the entire drive for depot repair if the HDA is defective.
- Do not attempt to disassemble the HDA. It is not field repairable. If the sealed HDA is opened by personnel not performing depot repair, this will damage components and void the warranty.
- As a component, this drive is designed to be installed and operated in accordance with UL1950, IEC950, EN60950, CSA C22.2 950, and VDE0805. Refer to Section 2 for information about installation.
- Ensure that the power supply meets the specifications in this manual and is designed to be used in accordance with UL1950, IEC950, EN60950, CSA C22.2 950, and VDE0805.

Seagate takes all reasonable steps to ensure that its products are certifiable to currently accepted standards. Typical applications of these disc drives include customer packaging and subsystem design. Safety agencies conditionally certify component assemblies, such as the Elite disc drive, based on their final acceptability in the end-use product. The subsystem designers are responsible for meeting these conditions of acceptability in obtaining safety/regulatory agency compliance in their end-use products and in certifying where required by law. A necessary part of meeting safety requirements is the provision for overcurrent protection on drive SELV supply voltages.

This unit is a component part and as such is not meant to comply with FCC or similar national requirements as a stand-alone unit. Engineering radiated and conducted emissions test results are available through the Seagate Safety Department to assist the subsystem designer.

Technical support services

Seagate Technology provides technical support literature and diagnostic utilities to authorized distributors. Please contact your dealer for technical support and installation troubleshooting. Product technical support is available for all Seagate products by calling the SeaFAX™, SeaFONE™, SeaTDD™, or SeaBOARD™ services. These are toll calls if you dial from outside of the number's local dialing area.

SeaFAX:

USA (408) 438-2620; England 44-62-847-7080

Use a touch-tone telephone to access Seagate's automated FAX system and select technical support information by return FAX. This service is available 24 hours a day, 7 days a week.

SeaFONE: (408) 438-8222

Technical support specialists are available from 8:00 A.M. to 5:00 P.M. PST, Monday through Friday. Recorded technical information for selected Seagate products is accessible 24 hours a day, 7 days a week.

SeaTDD: (408) 438-5382

TDD is a telecommunication device for the deaf where two people can communicate using a keyboard connected to the phone line. A TDD device is required to access this service, which is available from 8:00 A.M. to 5:00 P.M. PST, Monday through Friday.

SeaBOARD:

The Seagate Technical Support Bulletin Board System (BBS) is available 24 hours a day, 7 days a week. A modem is required to access this service. The communications software must be set for 8 data bits, no parity, and 1 stop bit (8N1). All BBS numbers operate at 9600 baud max. With this service you can access:

- Specifications and jumper configurations for Seagate products
- Reprints of Seagate documentation
- A directory of information and helpful utilities that you can download to your computer

| Location | Telephone number |
|----------------------------|-------------------------|
| USA, Mexico, Latin America | (408) 438-8771 |
| England | 44-62-847-8011 |
| Germany | 49-89-140-9331 |
| Singapore | 65-292-6973 |
| Australia | 61-2-756-2359 |
| Canada | (416) 856-5581 |
| France | 33-1-40-67-1034 |
| Korea | 82-2-556-7294 |

Section 1. General maintenance information

This section contains general information relating to maintenance of the drive. You should be familiar with the information in this section and with drive operation before attempting any maintenance procedures. Information is divided into the following areas:

- Maintenance tools and materials—lists the tools and materials required to perform maintenance on the drive
- Testing the drive—provides information concerning testing drive electronics, including a procedure for checking DC voltages supplied to the drive
- Identifying assemblies in the drive—identifies the various parts of the drive

Note. Refer to the user's manual (publication 83327720) for information about arranging for depot repair, removing and replacing a drive or power supply, and packing a drive for shipment.

Maintenance tools and materials

The procedures described in this section require the use of certain special tools, test equipment, and materials. These are listed below along with the Seagate part number. Note that the list includes only special tools. We assume that you have normal maintenance tools.

| Description | Seagate part number |
|--|--|
| Static ground wrist strap 6 1/2 to 8 inch wrist | 12263496 |
| Volt/ohmmeter | Ballantine 345 or equivalent digital voltmeter |

Testing the drive

During testing and troubleshooting, the drive normally performs various operations such as reading and writing test data. System software can be used to control the drive during these operations. Refer to manuals or other documentation applicable to the specific system or subsystem for information concerning the system software routines.

The drive also has built-in diagnostic tests. These diagnostic tests may be performed through the interface as described in Section 3.

The following procedure provides an overall check of the DC voltages used by the drive. Before performing this procedure, you should be familiar with the other information in this section and the safety information in the preface.

The illustration to the right shows where the individual voltages appear on the drive's DC power connector (J15).

Insert your test probe into the contact openings on the back surface of the 4-pin DC cable connector.

1. Using system software, command continuous read/write operations with the drive on a single cylinder.
2. Connect the voltmeter ground lead to J15 - Pin 3 (+5 V Return [Ground]).
3. Measure at the appropriate connection point to check the following voltages:

| Voltage | Connection | Specification |
|------------|-------------|----------------------|
| +5.0 volts | J15 - Pin 4 | +4.75 to +5.25 volts |
| +12 volts | J15 - Pin 1 | +11.4 to +12.6 volts |

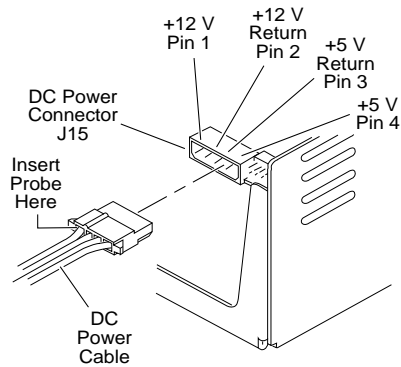

Identifying assemblies in the drive

The drive's major assemblies and components are shown in Figures 1 and 2. The components are supported by a chassis, and the head and disc assembly (HDA) is supported by shock mounts attached to the chassis. The control board is mounted above the HDA. The power board has a right-angle connection to one end of the control board. An optional bezel is available.

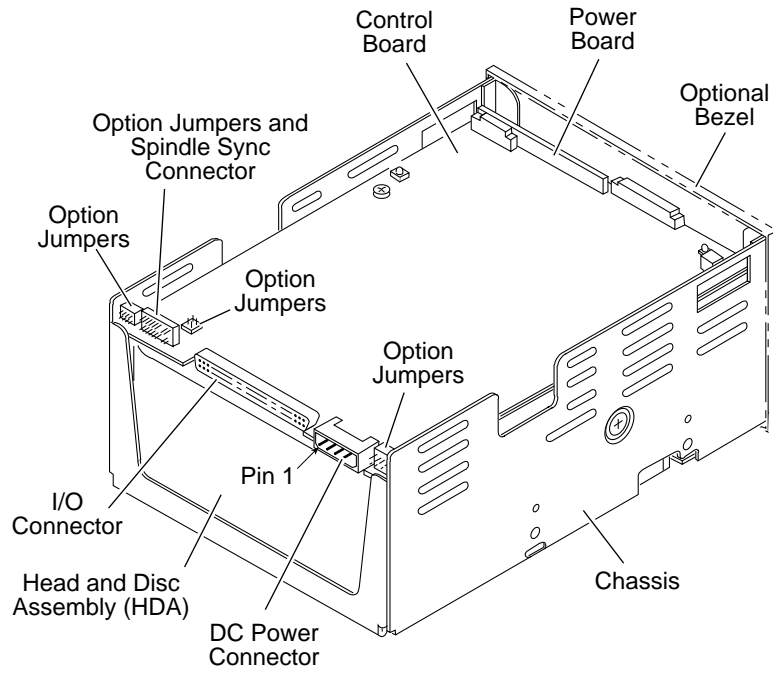

Figure 1. ST43401N/ND drive components

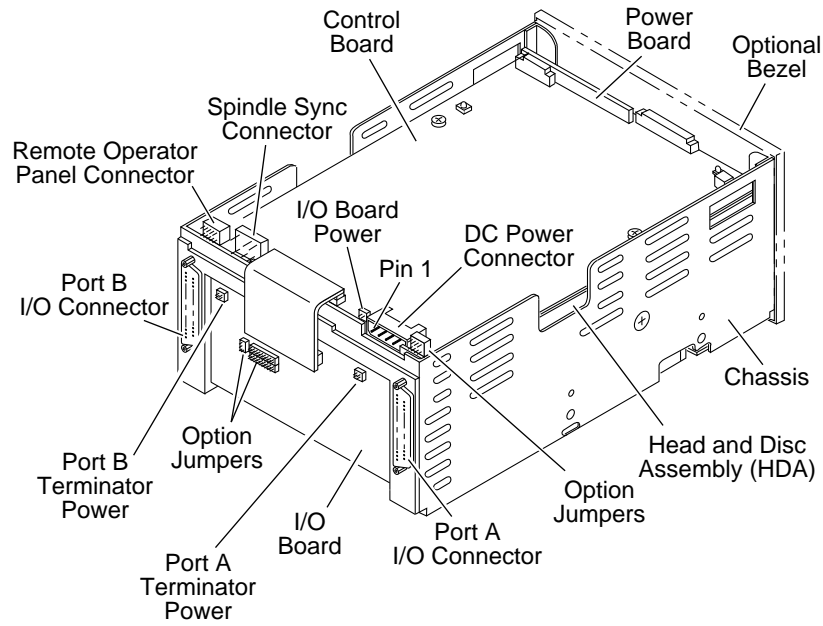

Figure 2. ST43402ND drive components

Section 2. Planning the system

This section supplements the installation instructions presented in the user's manual (publication 83327720). To aid in configuring the drive for specific system requirements, the following subjects are discussed:

- Guidelines for enclosure design
- Guidelines for proper air flow
- Guidelines for I/O cabling
- Using the sweep cycle function

Guidelines for enclosure design

The drive is a component for installation in an enclosure that you have designed. The enclosure design must provide for mounting the drive and power supply, cable routing, and cooling. See the next topic for guidelines on providing proper cooling.

The system designer is responsible for obtaining any needed agency approvals such as UL, CSA, and VDE.

Figure 3 provides mounting dimensions for ST43401N/ND and ST43402ND drives without a bezel. Figure 4 provides the same information for ST43401N/ND drives with the optional bezel attached. As described in the user's manual, the drive can be mounted using either side-mounting screws or bottom-mounting screws.

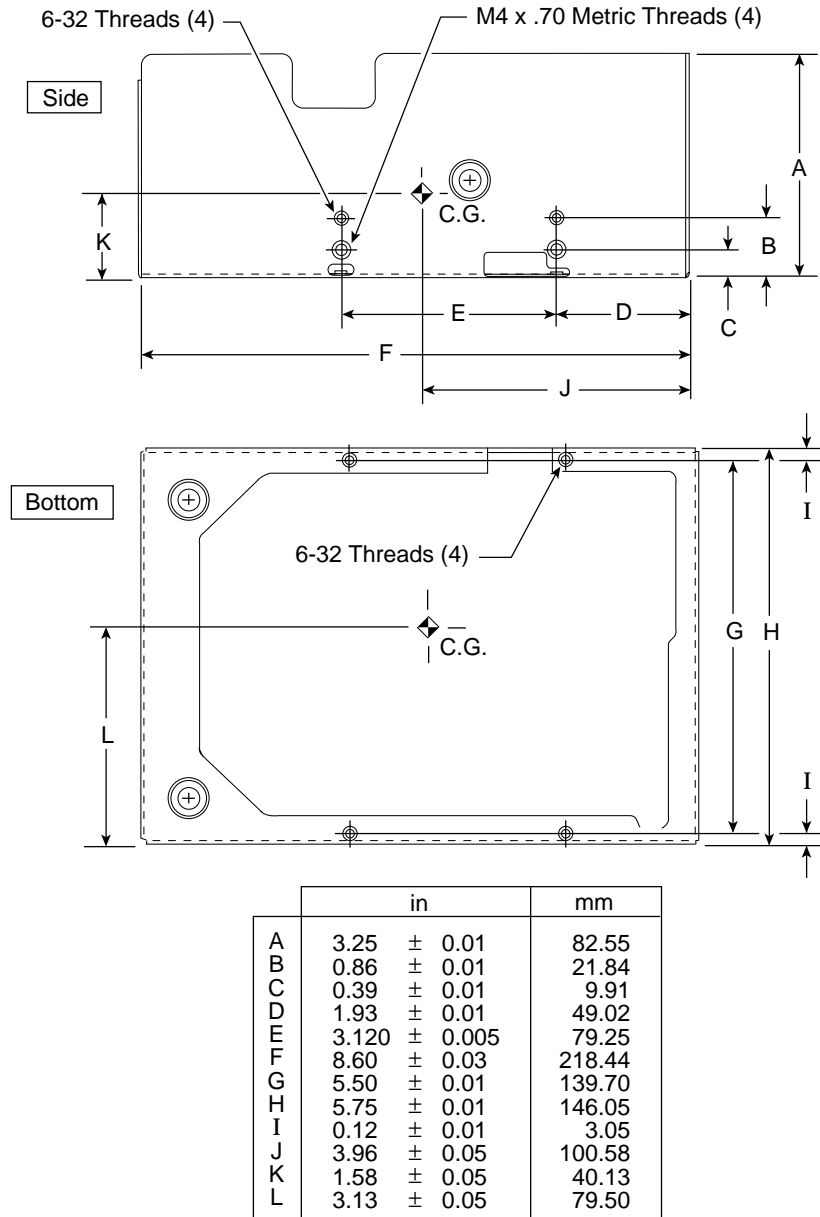
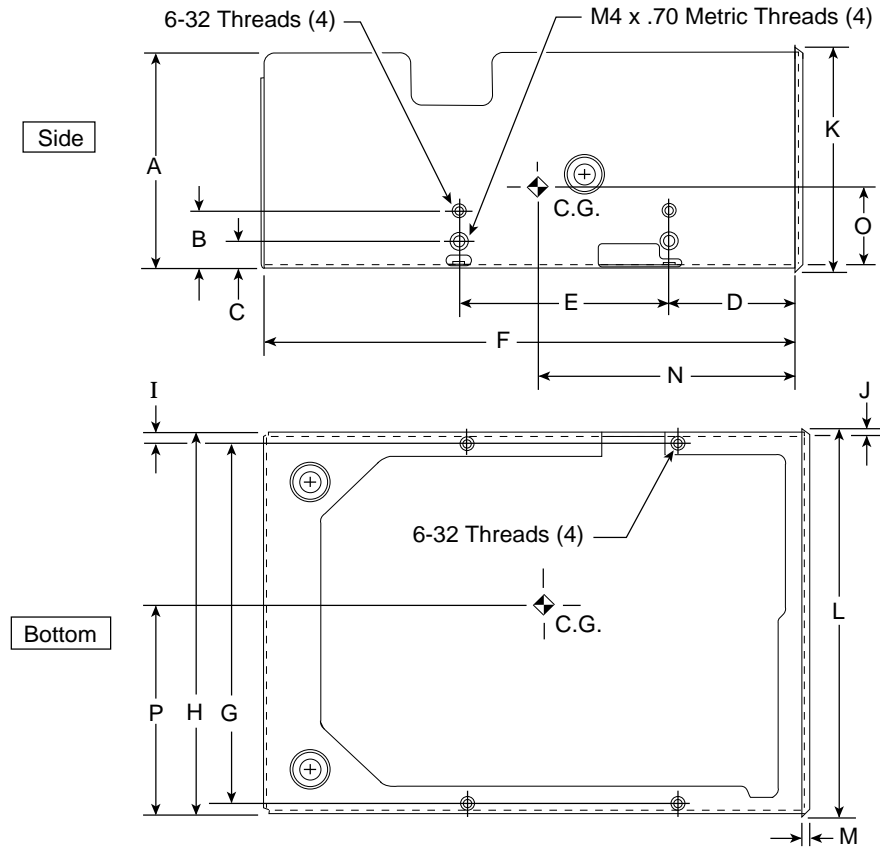

Figure 3. Mounting dimensions for ST43401N/ND and ST43402ND drives without a bezel



| | in | mm |
|---|---------------|--------|
| A | 3.25 ± 0.01 | 82.55 |
| B | 0.86 ± 0.01 | 21.84 |
| C | 0.39 ± 0.01 | 9.91 |
| D | 1.87 ± 0.02 | 47.50 |
| E | 3.120 ± 0.005 | 79.24 |
| F | 8.00 max | 203.20 |
| G | 5.50 ± 0.01 | 139.70 |

| | in | mm |
|---|-------------|--------|
| H | 5.75 ± 0.01 | 146.05 |
| I | 0.12 ± 0.01 | 3.05 |
| J | 0.06 ± 0.02 | 1.52 |
| K | 3.38 ± 0.02 | 85.85 |
| L | 5.88 ± 0.01 | 149.35 |
| M | 0.19 ± 0.01 | 4.83 |
| N | 3.90 ± 0.05 | 99.06 |
| O | 1.58 ± 0.05 | 40.13 |
| P | 3.13 ± 0.05 | 79.50 |

Figure 4. Mounting dimensions for ST43401N/ND with a bezel

Guidelines for proper air flow

Your enclosure design must ensure adequate cooling for the drive.

We recommend orienting the drive or directing the air flow in a way that creates the least amount of air-flow resistance while providing air flow above the circuit boards and around the head and disc assembly (HDA). Also, choose the shortest possible path between the air inlet and exit. This minimizes the distance traveled by air that is heated by the drive and by other nearby heat sources.

Figure 5 shows the design approach with one or more fans installed. The air-flow patterns can be created by the fans either pushing or drawing air. The overall flow pattern can be directed from front to back, back to front, or side to side.

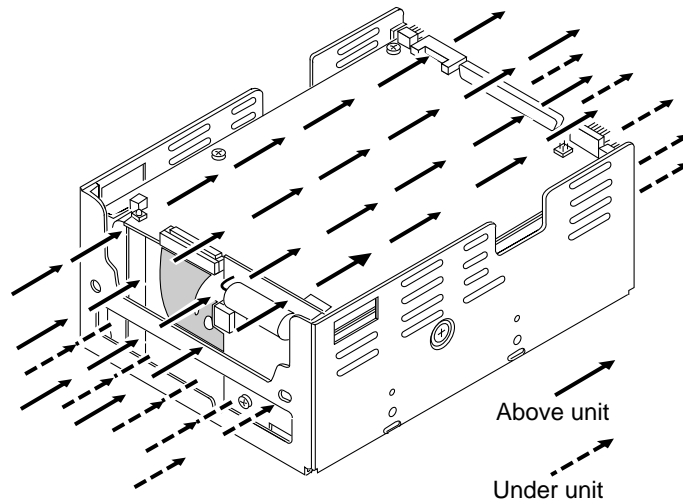

Note. Air flows in the direction shown (front to back) or in reverse direction (back to front)

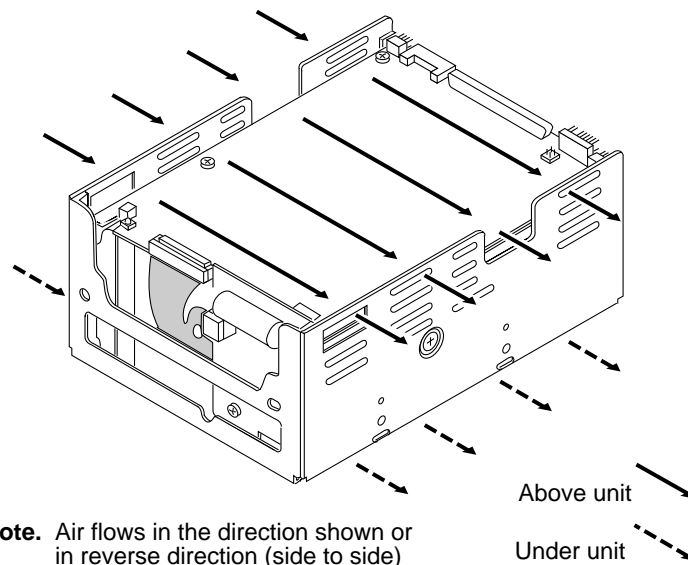

Note. Air flows in the direction shown or in reverse direction (side to side)

Figure 5. Suggested air flow

To evaluate the air-flow design, place the drive in its final mechanical position and perform random read and write operations. After the temperatures stabilize, measure the surface (case) temperatures of the components listed in the appropriate table below. The mean time between failures (MTBF) values assume that the drive operates below the specified reliability guidelines.

Table 1. ST43401N/ND air-flow evaluation

| Card | Component | Reference | Office | Computer | Max allowable case temp* |
|--------|---------------|-----------|---|--|--------------------------------|
| | | | environment MTBF 200k hours case temp* | room MTBF 300k hours case temp* | |
| S/RVFX | PERI-2 | D540 | 45 | 35 | 60 |
| S/RVFX | Video AMP | F826 | 55 | 45 | 70 |
| S/RVFX | RDS | G115 | 55 | 45 | 70 |
| S/RVFX | ECLTTL | D212 | 47 | 37 | 62 |
| S/RVFX | SCRAM | C051 | 44 | 34 | 59 |
| S/RVFX | DRAM | B405 | 42 | 32 | 57 |
| FYEX | Motor control | U10(A211) | 51 | 41 | 66 |
| | HDA housing | Figure 6 | | | 60 |

*Temperature in °C

Table 2. ST43402ND air-flow evaluation

| Card | Component | Reference | Office | Computer | Max allowable case temp* |
|------|---------------|------------|---|--|--------------------------------|
| | | | environment MTBF 200k hours case temp* | room MTBF 300k hours case temp* | |
| AYGX | PERI-2 | U40 (D540) | 45 | 35 | 60 |
| AYGX | Video AMP | U44 (F826) | 52 | 42 | 67 |
| AYGX | RDS | U56 (G115) | 56 | 46 | 71 |
| AYGX | ECLTTL | U33 (D709) | 46 | 36 | 61 |
| AYGX | SCRAM | U6 (B145) | 45 | 35 | 60 |
| AYGX | Driver | U26 (B107) | 45 | 35 | 60 |
| FYEX | Motor control | U10 (A211) | 49 | 39 | 64 |
| BYGX | ECLTTL | U7 (D417) | 52 | 42 | 67 |
| | HDA housing | Figure 6 | | | 60 |

*Temperature in °C

Guidelines for I/O cabling

This topic provides recommendations for I/O cabling and lists the parts that can be used in various cables. There are three general cabling schemes, as illustrated in the following figures:

- Figure 7 describes how to design cables when the initiator and all the drives are located in one cabinet
- Figure 8 describes how to design cables when the initiator is located in one cabinet and all the drives are located in another cabinet
- Figure 9 describes how to design cables when the initiators and drives are distributed within three cabinets

Refer to the appropriate figure to determine the types of components required for your installation. All three figures show how drives inside a cabinet are connected by continuous unshielded I/O cables that have a connector for each drive. In some cases, these internal cables connect to a bulkhead that allows external shielded cables to be connected. Shielded cables must be used if the cables run between cabinets.

Cumulative cable length in a daisy-chain system cannot exceed 25.0m (82.0 ft) for drives using differential I/O. With single-ended I/O, cumulative cable length cannot exceed 3.05m (10.0 ft).

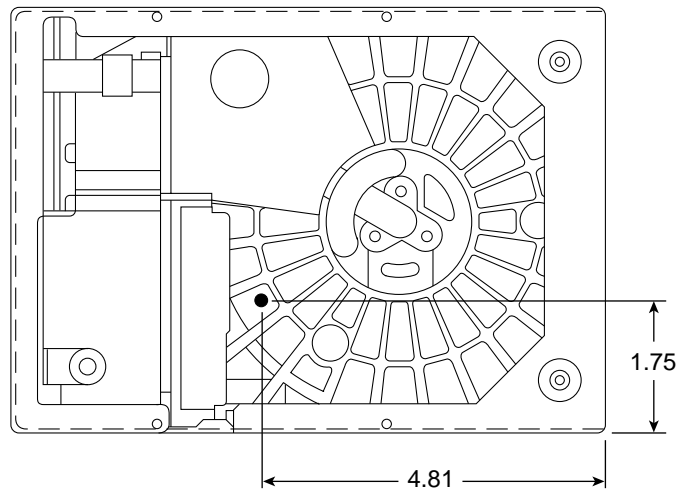
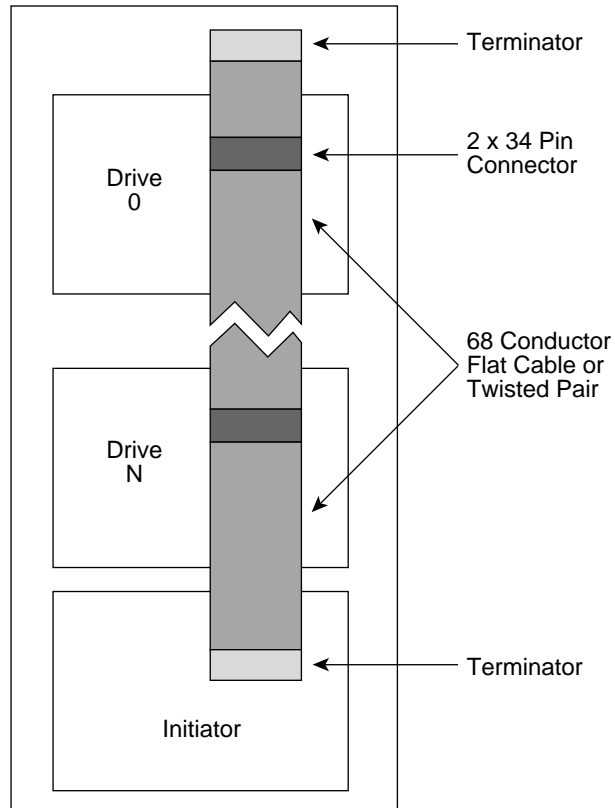

Figure 6. Temperature measurement location on the HDA (bottom)

Drives and initiator in one cabinet**Notes:**

1. Cables and terminators shown are unshielded.
2. Flat cable can be used with single-ended drivers. Twisted-pair flat cable must be used with differential drivers.
3. Total length of cables and stubs cannot exceed 25m (82.0 ft) with differential drivers or 3.05m (10.0 ft) with single-ended drivers.

Figure 7. Cabling with one cabinet

Drives and initiator in separate cabinets

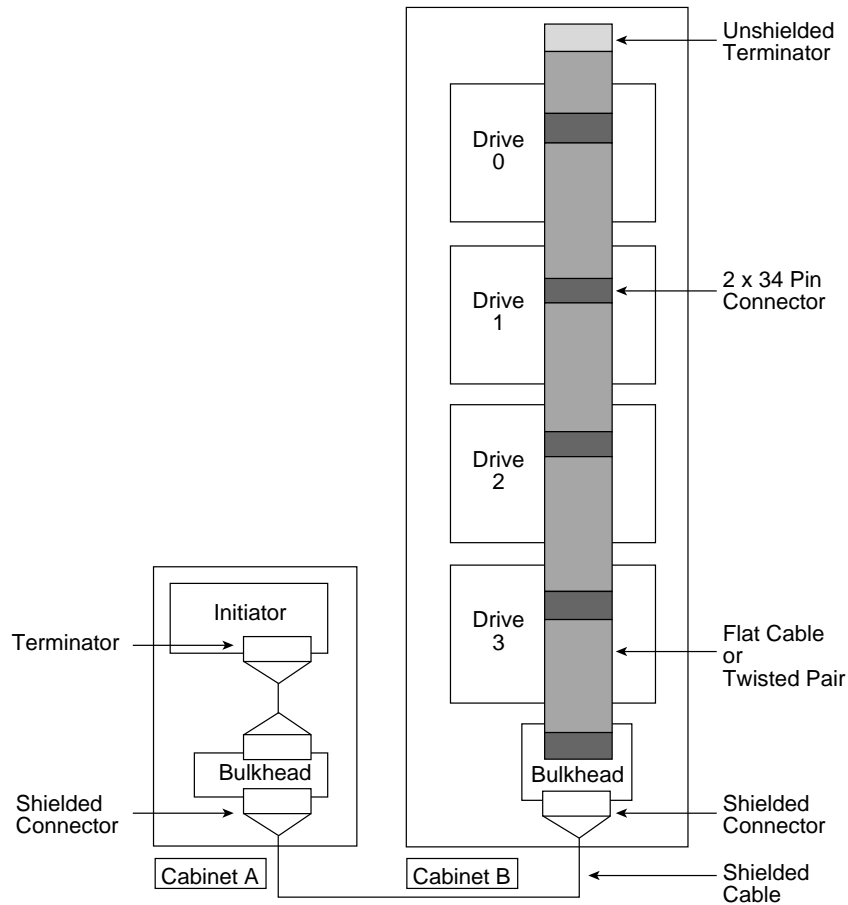

Notes:

1. Initiator in one cabinet (A).
2. All drives in another cabinet (B).
3. Both bulkheads have shielded connectors.
4. Flat cable can be used with single-ended drivers. Twisted-pair flat cable must be used with differential drivers.
5. Total length of cables and stubs cannot exceed 25m (82.0 ft) with differential drivers or 3.05m (10.0 ft) with single-ended drivers.

Figure 8. Cabling with two cabinets

Drives in separate cabinets

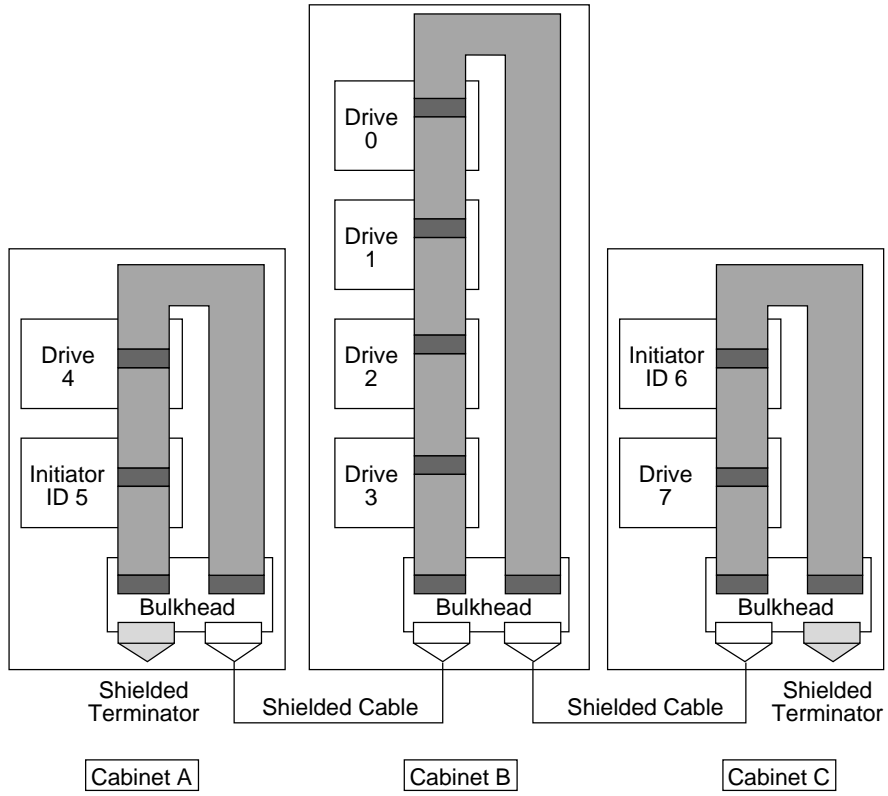

Figure 9. Cabling with three cabinets

Table 3 lists the parts needed to construct unshielded I/O cables. Table 4 lists part numbers and lengths of synchronized spindle cables. Table 5 provides part numbers of external terminators and resistor-pak terminators.

ST43402ND (dual port) drives have both I/O connectors (one for Port A and the other for Port B) located on the I/O board. You must use an adapter (part number 70935801) to terminate each I/O cable following the last drive in the daisy chain.

ST43401N/ND (single-ended) drives are shipped with resistor-pak terminators installed on the control board. Each end of the daisy-chain I/O cable must be terminated. If the resistor-pak terminators are in place on the drive, external terminators are not needed. Single-ended terminators and differential terminators have different part numbers and electrical characteristics (they cannot be interchanged).

Table 3. Unshielded I/O cabling components

| Vendor part number | Description |
|-------------------------------|--|
| Connectors for cable ends | |
| AMP-786090-7 | Connector, unshielded male, straight |
| Connectors in daisy chain | |
| AMP-786096-7 | Connector, shielded male, straight (two used per cable) |
| Cable | |
| Hitachi-A3007-51-68T | Flat cable, twisted-pair, 68-conductor, 30 AWG (for single-ended or differential I/O) |

Table 4. Synchronized spindle cables

| Length | Seagate part number |
|-----------------------|--------------------------------|
| 1.5 feet (0.46 meter) | 70703929 |
| 3 feet (0.91 meter) | 70703921 |
| 5 feet (1.52 meter) | 70703922 |
| 7 feet (2.13 meter) | 70703923 |
| 10 feet (3.05 meter) | 70703924 |
| 20 feet (6.09 meter) | 70703925 |
| 30 feet (9.14 meter) | 70703926 |
| 40 feet (12.19 meter) | 70703927 |
| 50 feet (15.24 meter) | 70703928 |

Table 5. Terminators

| Description | Seagate part number |
|--|--------------------------------|
| Terminator resistor-pak, single-ended | 96752447 |
| Terminator resistor-pak, differential | 70906701 |
| Terminator, external shielded single-ended | 89501152 |
| Terminator, external shielded differential | 89501030 |
| Terminator, external unshielded single-ended | 15387807 |
| Terminator, external unshielded differential | 15459255 |
| Terminator, adapter for dual-port drives | 70935801 |

Using the sweep cycle function

The sweep cycle is a feature that periodically moves the heads to different locations on the discs during intervals when the drive is idle. The following are highlights of the sweep cycle function:

- Using the sweep cycle enhances drive reliability. We encourage you either to enable the drive sweep cycle or to use a sweep cycle controlled by the host (initiator). Consult with an analyst in making this choice.
- The sweep routine consumes approximately 11 seconds of a 13-hour period. The drive is available to the system more than 99.98 percent of the time.
- You may disable the sweep cycle (described below) without affecting the specified mean time between failures (MTBF) or warranty agreements.

The drive is preset during manufacturing with the sweep cycle option selected. A jumper on the control board makes the selection, as shown in Figure 10. The other jumpers on the control board are discussed in the user's manual.

The jumper is identified as Sweep Cycle Option, which either enables or disables the sweep cycle function. The jumper can be positioned as follows:

- Jumper disconnected—disables the sweep cycle function
- Jumper connected—enables the sweep cycle function

Sweep movements, if enabled, can occur only in conjunction with seeks required by the controller or with any SCSI read or write operation having an implied seek. Each time the drive performs a sweep cycle, it starts a 12-minute timeout. When the timeout has elapsed, the drive performs another sweep cycle only when it receives the Seek command. When combining a sweep cycle with a seek, the drive performs the sweep cycle first and then executes the Seek command.

If a sweep segment was initiated by the Seek command, the drive performs the sweep function and then moves the heads to the cylinder requested by the controller. If about 15 minutes elapse with no disc access commands received from the SCSI bus, the SCSI I/O logic sends a one-track seek command to the drive logic. This command causes the drive to perform its sweep cycle.

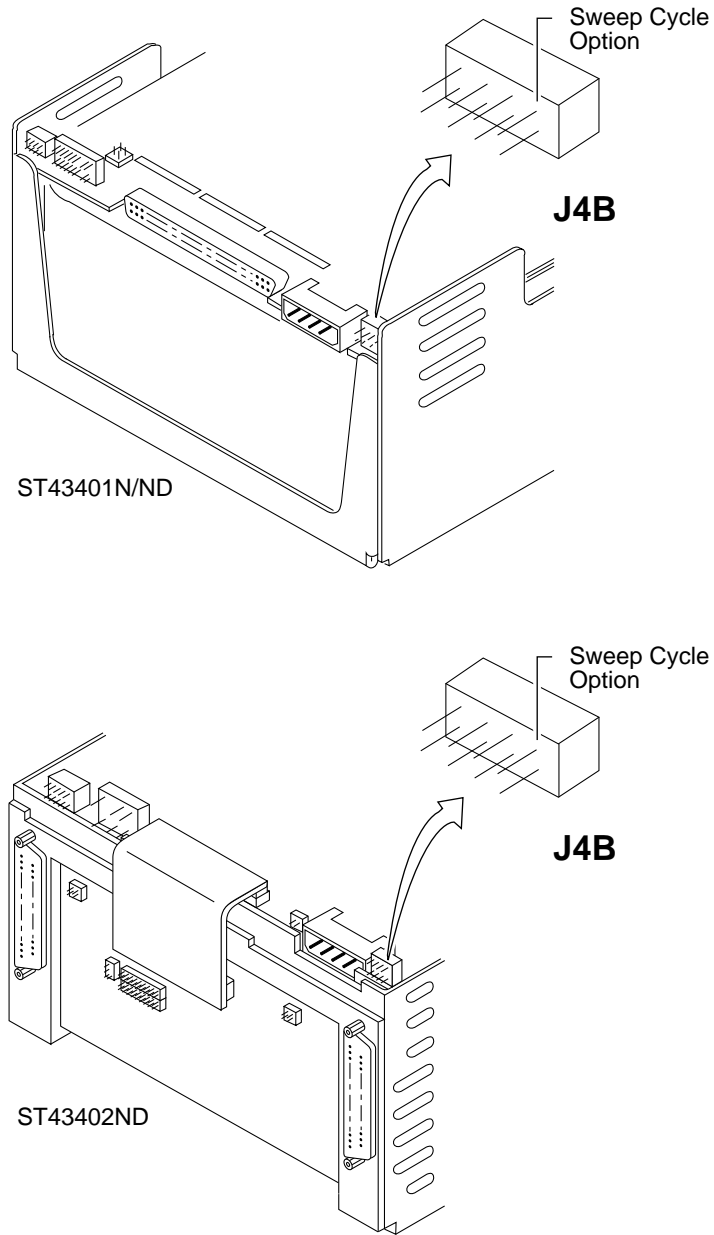

Figure 10. Control board jumpers

Section 3. Interface functions

This section provides an overview of the small computer system interface (SCSI) as it is used in the Elite drive. It is beyond the scope of this manual to provide a detailed description of all the features, capabilities, variations, and protocol of SCSI-2. This information is provided in the SCSI Interface Specification for the Elite Product Family (document 64721702).

All communications between drive and controller must pass through the interface. This communication includes all commands, status, control signals, and read/write data transfers. The interface consists of the I/O cables and the logic (on part of the control board) required to process the signals sent between the drive and controller.

Dual port drive (ST43402ND) considerations

ST43402ND dual port drives have some different operating limits from the single port drives discussed in this manual. These differences are listed below.

- Dual port drives have separate sense buffers, synchronous transfer agreements, and unit attention conditions for each initiator on both ports.
- Any initiator may place commands in the queue on either port.
- Data placed in the cache by one port may be used to satisfy a read request from the other port. A write from one port may cause data cached by a read request from the other port to be purged from the cache.

SCSI bus configuration

Figure 11 illustrates the SCSI bus configuration. The SCSI bus can have a maximum of 16 devices connected to it, and communication can occur between any 2 devices at any given time. The device that originates an operation is referred to as the initiator and the device that performs the operation is the target.

The drive uses one unshielded I/O cable to attach it to the SCSI bus. You must supply all unshielded cables (see “Guidelines for I/O cabling” in Section 2). Shielded cables are typically used for connections between cabinets where electromagnetic compatibility (EMC) and electrostatic discharge (ESD) protection are required. The I/O cable carries commands, data, and status information across the SCSI bus. Figure 12 shows the lines (except those not used) in the I/O cable. The function of each of these lines is explained in Table 6.

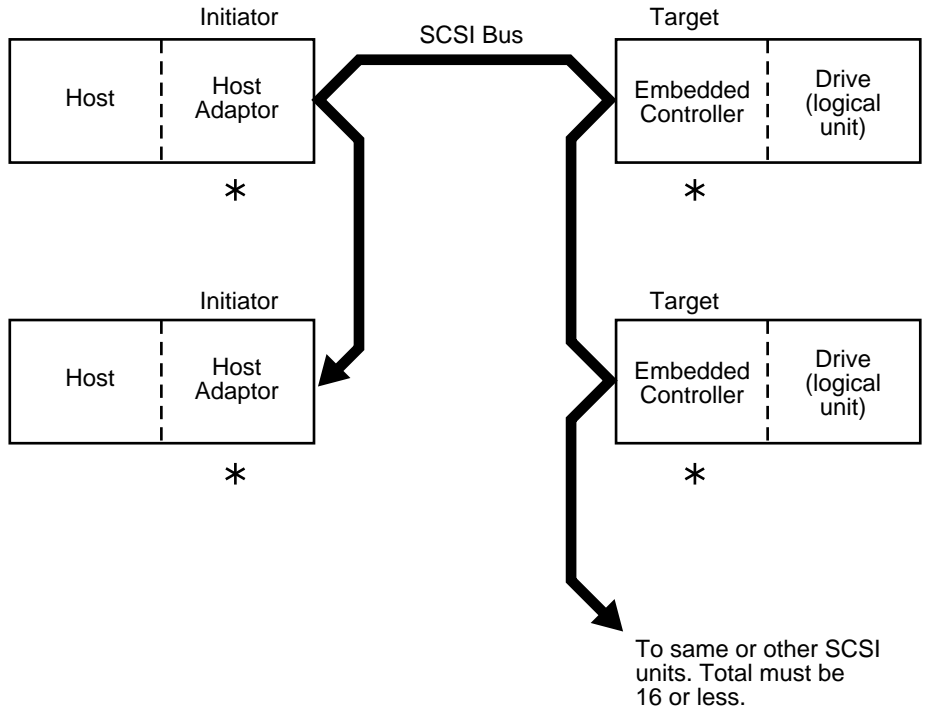

* Each device must have a unique SCSI ID, assigned by its SCSI ID bit.

| | | | | | | | | |
|--------------|--------|--------|--------|--------|--------|--------|--------|--------|
| Data Bus Bit | DB (7) | DB (6) | DB (5) | DB (4) | DB (3) | DB (2) | DB (1) | DB (0) |
| SCSI ID | 7 | 6 | 5 | 4 | 3 | 2 | 1 | 0 |

| | | | | | | | | |
|--------------|---------|---------|---------|---------|---------|---------|--------|--------|
| Data Bus Bit | DB (15) | DB (14) | DB (13) | DB (12) | DB (11) | DB (10) | DB (9) | DB (8) |
| SCSI ID | 15 | 14 | 13 | 12 | 11 | 10 | 9 | 8 |

Figure 11. SCSI bus configuration

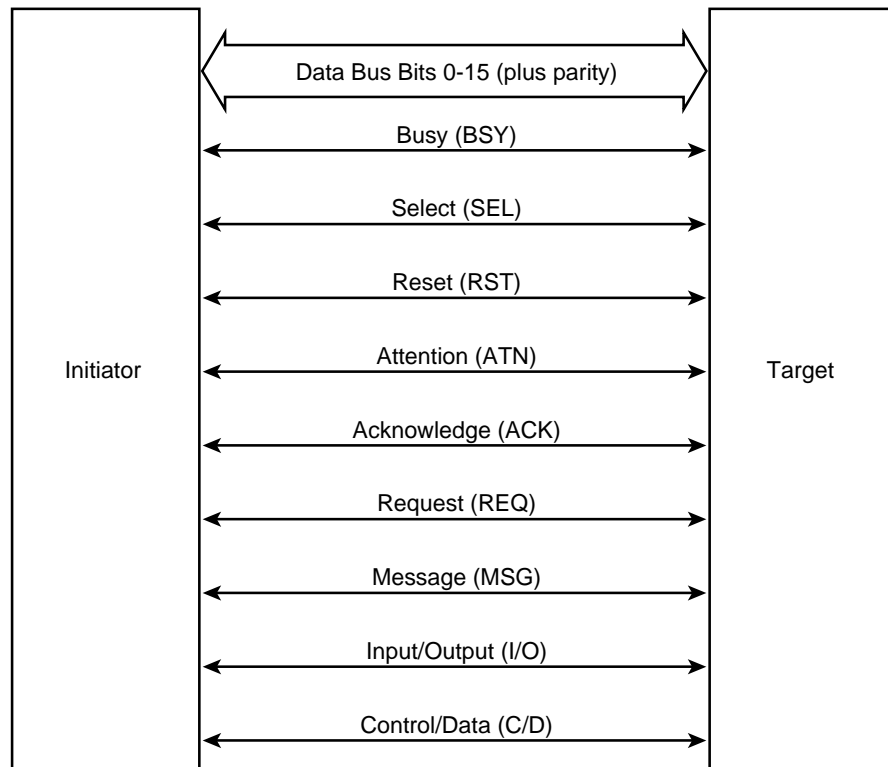

Figure 12. SCSI bus signal lines

Table 6. SCSI bus signal lines

| Signal | Source | Function |
|----------------------|---------------|--|
| Data Bus (DB 15–0+P) | I–T | Sixteen data-bit signals, plus a parity bit signal that form the Data Bus. DB(15) is the most-significant bit and has the highest priority during the Arbitration phase. Bit number, significance, and priority decrease downward to DB(0). A data bit is defined as 1 when the signal is true and 0 when false. Data parity DB(P) is odd. The use of parity is a selectable option and is not valid during the Arbitration phase. |
| Busy (BSY) | I–T | An “or-tied” signal that indicates to the initiator or target that the bus is being used. |
| Select (SEL) | I–T | Used by an initiator to select a target, or by a target to reselect an initiator. |
| Reset (RST) | I–T | An “or-tied” signal that indicates the Reset condition exists. |
| Attention (ATN) | I | Driven by the initiator to indicate an Attention condition. |
| Acknowledge (ACK) | I | Driven by the initiator to acknowledge a REQ/ACK data transfer handshake. |
| Request (REQ) | T | Driven by the target to indicate a request for a REQ/ACK data transfer handshake. |
| Message (MSG) | T | Driven by target during the Message phase. |
| Input/Output (I/O) | T | Driven by the target to control the direction of data movement on the data bus with respect to the initiator. True indicates input to the initiator. Also used to distinguish between Selection and Reselection phases. |
| Control/Data (C/D) | T | Driven by the target to indicate whether control or data information is on the data bus. True indicates control. |

T = target and I = initiator

I/O signal processing

The following paragraphs describe the basic SCSI bus communication process. They describe the bus phases, a typical command sequence, command set, and message codes. The Request Sense command and the Receive Diagnostic Results command provide information to the initiator about drive functions. The coding of this information is explained later in this section.

SCSI bus phases

Communication on the SCSI bus occurs in eight phases depending on the type of operation or information transfer being performed. The bus phases pertain to the condition or state of the lines at a given time. The SCSI bus can never be in more than one phase at any given time.

The information phases are defined by the MSG, C/D, and I/O signals as shown in Table 7. The SCSI bus phases are listed and described in Table 8.

Table 7. Information transfer phases

| MSG | C/D | I/O | Phase Name | Direction of Transfer |
|-----|-----|-----|-------------|------------------------|
| 0 | 0 | 0 | Data Out | Initiator-----> Target |
| 0 | 0 | 1 | Data In | Target-----> Initiator |
| 0 | 1 | 0 | Command | Initiator-----> Target |
| 0 | 1 | 1 | Status | Target-----> Initiator |
| 1 | 0 | 0 | Reserved | |
| 1 | 0 | 1 | Reserved | |
| 1 | 1 | 0 | Message Out | Initiator-----> Target |
| 1 | 1 | 1 | Message In | Target-----> Initiator |

0 = false, 1 = true

Table 8. SCSI bus phase descriptions

| Phase | Description |
|--------------|--|
| Bus Free | No SCSI device asserts Busy or Select for at least one bus settle delay. |
| Arbitration | Allows one SCSI device to gain access to the bus based on its priority ID bit. |
| Selection | Allows an initiator to select a target. The I/O line must not be asserted in this phase. |
| Reselection | Allows a target to reconnect to an initiator so it can continue an operation started by an initiator but suspended by the target before it was complete. The I/O line must be asserted during this phase. |
| Command | Allows the target to request command information from the initiator. |
| Data | The Data In phase allows the target to request that data be sent to the initiator from the target. The Data Out phase allows the target to request that data be sent from the initiator to the target. |
| Status | Allows the target to request that status information be sent from the target to the initiator. |
| Message | The Message In phase allows the target to request that messages be sent to the initiator from the target. The Message Out phase allows the target to request that messages be sent from the initiator to the target. The target can invoke this phase at its convenience in response to an Attention signal created by the initiator. |

SCSI command execution

Figure 13 illustrates the basic flow of a command sequence. The sequence illustrated cannot and does not represent all variations. Refer to the SCSI Interface Specification for the Elite Product Family (document 64721702) for command descriptions, execution details, and timing constraints. The following information appears at the end of this topic:

- Table 9 describes the command set for the drive
- Table 10 lists the message codes and shows the direction of flow for each
- Table 11 describes the status codes

As shown in Figure 13, the communication sequence starts with the SCSI bus in the Bus Free phase. This phase indicates that no other SCSI devices are using the bus and it is free for use by other devices. Each device detects the Bus Free phase when the Select and Busy lines are both false.

The Bus Free phase is followed by an Arbitration phase where the initiator attempts to gain access to the bus. Access to the bus is based on the device priority ID bit. Arbitration occurs when the device asserts Busy and its ID on the data bus. This ID bit is a single bit on the data bus that corresponds to the unique SCSI address assigned to each device when it was installed. The other 15 bits are released by the SCSI device. The SCSI device examines the data bus. If a higher priority SCSI ID bit is true (data bus bit 15 is the highest) the SCSI device loses arbitration and the device releases its signals. If no higher priority bit is true, the device wins arbitration.

After winning the Arbitration, the initiator selects the target (Selection phase). The initiator places the SCSI ID of the target on the bus (asserts the data bus bit), as well as its own ID. After a delay, the initiator asserts the Select line. The target determines it is selected when its SCSI bus ID bit and the Select line are true, and the Busy and I/O lines are false. Selection with Attention informs the target that the initiator has a message ready.

Note. For dual port drives, a SCSI hard reset causes a unit attention condition for all initiators on the port receiving the reset. Commands, reservations, wide negotiations, and synchronous negotiation agreements associated with the alternate port are not affected.

The selected device responds to the initiator by entering the Message Out phase if the initiator has Attention asserted. In this phase, the target requests that the initiator send messages to it. The Message, Control/Data, and Input/Output lines are used in combinations to indicate the various information transfer phases. The state of the three signal lines is controlled by the target, and the phase selected by the state of these three signal lines is shown earlier in Table 7.

In this example, the Identify message is the first message sent by the initiator after the Selection phase. This message identifies the physical path for the logical unit (only logical unit 0 is supported) specified by the initiator. The Identify message is also the first message sent by the target following the Reselection phase. The initiator can request a Message Out phase by asserting Attention.

Following the Message Out phase, the initiator responds to the Command phase and, in this example, issues a Read command to the drive. The Message In phase is entered (Disconnect message) followed by the Bus Free phase. The Arbitration phase is again entered, followed by the Reselection and the Message In (Identify message) phases. Reselection is a phase that allows the target to reconnect to the initiator so it can continue an operation that was started by an initiator but suspended by the target before it was complete. The requested read data is then transferred to the initiator.

Following the Data In phase, the target enters the Message In phase and, in this example, requests the initiator to Save Data Pointer. There are current (also called active) pointers that represent the state of the interface and point to the next command, data, or status byte to be transferred between the initiator's memory and the target. Current pointers are used with the target currently connected to the initiator.

Another set of pointers called saved pointers is provided for each active command, whether or not it is currently connected. The command pointer points to the start of the command descriptor block for that command. The saved data pointer points to the start of the data area at the beginning of each command and it remains at this value until the target sends the Save Data Pointer message to the initiator. In response to this message, the initiator stores the value of the current data pointer into the saved data pointer. Only the saved pointer values are retained when a device disconnects from the bus. The current pointer values are restored from the saved values at the next reconnection.

At this point, the Message In phase is entered with a Disconnect message code. Following the disconnect, the bus is in the Bus Free phase in preparation for the Arbitration and Reselection phases.

After Reselection, the process continues with the Message In and Data In phases previously described. The Status phase occurs at the end of the operation. It allows the target to send status information to the initiator. Status codes are contained in bits 5 to 1 of the status byte. The various codes are shown in Table 11. The process ends with the Message In phase and a Command Complete message followed by the Bus Free phase.

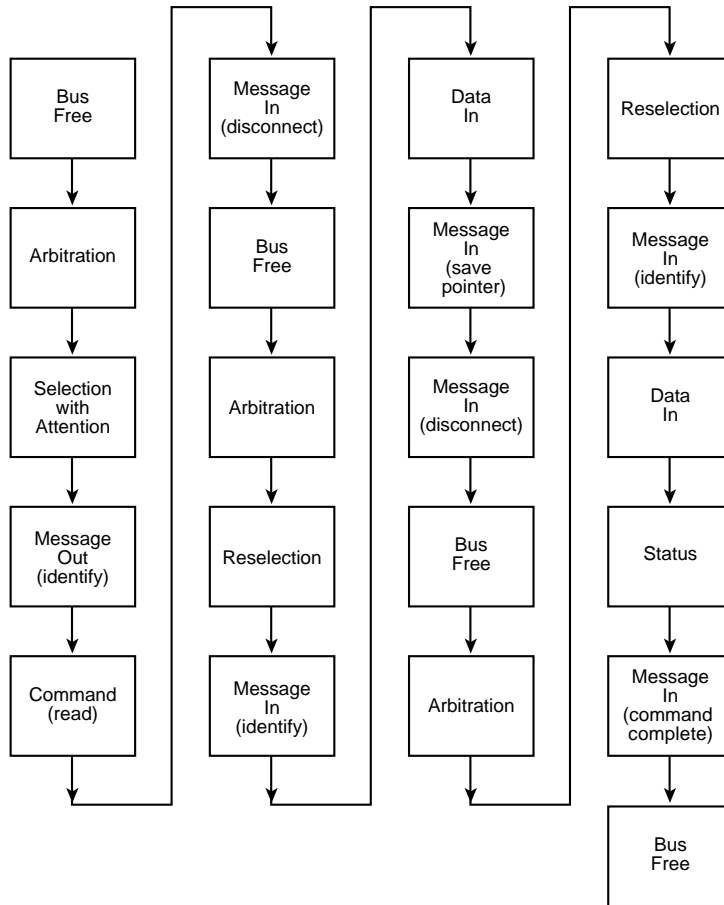

Figure 13. Sequence of a typical command

Table 9. Command set**Group 0 commands for direct access devices**

| Op code | Command name |
|----------------|--------------------------------|
| 00 | Test Unit Ready |
| 01 | Rezero Unit |
| 02 | |
| 03 | Request Sense |
| 04 | Format Unit |
| 05–06 | |
| 07 | Reassign Blocks |
| 08 | Read |
| 09 | |
| 0A | Write |
| 0B | Seek |
| 0C–10 | |
| 11 | Port Status (0 dual port only) |
| 12 | Inquiry |
| 13–14 | |
| 15 | Mode Select |
| 16 | Reserve (see note 1) |
| 17 | Release |
| 18–19 | |
| 1A | Mode Sense (see note 2) |
| 1B | Start/Stop Unit |
| 1C | Receive Diagnostic Results |
| 1D | Send Diagnostic |
| 1E–1F | |

Note 1. For dual port drives, when a reservation is granted to an initiator on one port, all initiators on both ports receive reservation conflict status.

Note 2. Dual port drives do not support Mode Sense. Dual port drives support Expanded Mode Sense (page 08h), which includes all previous functions supported by Mode Sense (page 38h).

continued

continued from previous page

Group 1 and 2 Commands for Direct Access Devices

| Op Code | Command Name |
|----------------|---------------------|
| 20–24 | |
| 25 | Read Capacity |
| 26–27 | |
| 28 | Read Extended |
| 29 | |
| 2A | Write Extended |
| 2B | Seek Extended |
| 2C–2D | |
| 2E | Write and Verify |
| 2F | Verify |
| 30–36 | |
| 37 | Read Defect Data |
| 38–3A | |
| 3B | Write Buffer |
| 3C | Read Buffer |
| 3D | |
| 3E | Read Long |
| 3F | Write Long |
| 40 | Change Definition |

Table 10. Message code descriptions

| Code (Hex) | Initiator | Target | Description | Direction of Transfer |
|-----------------------|------------------|---------------|---|------------------------------|
| 00 | M | M | Command complete | Target -----> Initiator |
| 01//00 | O | O | Modify data pointer | Target -----> Initiator |
| 01//01 | O | O | Sync data transfer request | Target <-----> Initiator |
| 02 | O | O | Save data pointer | Target -----> Initiator |
| 03 | O | O | Restore pointers | Target -----> Initiator |
| 04 | O | O | Disconnect | Target -----> Initiator |
| 05 | O | M | Initiator detected error | Initiator -----> Target |
| 06 | O | M | Abort | Initiator -----> Target |
| 07 | M | M | Message reject | Target <-----> Initiator |
| 08 | M | M | No operation | Initiator -----> Target |
| 09 | M | M | Message parity error | Initiator -----> Target |
| 0A | O | O | Linked command complete | Target -----> Initiator |
| 0B | O | O | Linked command complete with flag | Target -----> Initiator |
| 0C | O | M | Bus device reset (see note 1) | Initiator -----> Target |
| 0D | O | M | Abort tag | Initiator -----> Target |
| 0E | O | O | Clear queue (see note 2) | Initiator -----> Target |
| 0F-13 | | | Reserved | — — |
| 14 | O | O | Reset other port message | Initiator -----> Target |
| 15-1F | | | Reserved | — — |
| 20 | O | O | Simple queue tag (two bytes) | Target <-----> Initiator |
| 21 | O | O | Head of queue tag (two bytes) | Initiator -----> Target |
| 22 | O | O | Ordered queue tag (two bytes) | Initiator -----> Target |
| 23-7F | | | Reserved | — — |
| 80-FF | M | M | Identify (establishes the communication path between an initiator and target for a logical unit) | Target <-----> Initiator |

continued

continued from previous page

- Bit 7 = 1: Indicates an Identify message
- Bit 6 = 1: Indicates the initiator allows disconnection and reselection
- Bit 6 = 0: Indicates that disconnection is not allowed
- Bit 5 = 0: Indicates the I/O is directed to or from a logical unit
- Bit 5 = 1: Indicates the I/O is directed to or from a target routine
- Bits 4 to 3: Reserved
- Bits 2 to 0: Specify a logical unit number or target routine number, depending on bit 5
- M = Mandatory for SCSI-2
- O = Optional for SCSI-2

Note 1. For dual port drives, a bus device reset message from either port causes a unit attention condition for all initiators on both ports. Commands, reservations, wide negotiations, and synchronous negotiation agreements associated with the alternate port are not affected.

Note 2. For dual port drives, a clear queue message from either port causes all commands from that port to be cleared. A unit attention condition is set for all initiators on that port except the one that sent the Clear Queue message. Commands for the other port are not affected.

Table 11. Status codes**Status Byte:**

| Byte | Bit | | | | | | | 0 |
|------|-------|-------|----------------------------------|---|---|---|---|-------|
| | 7 | 6 | 5 | 4 | 3 | 2 | 1 | |
| | RESVD | RESVD | <<----- Status Byte Code ----->> | | | | | RESVD |

Status Byte Codes:

| Bits of the Status Byte* | | | | | | | | Status Description |
|-------------------------------|---|---|---|---|---|---|---|----------------------------|
| 7 | 6 | 5 | 4 | 3 | 2 | 1 | 0 | |
| 0 | 0 | 0 | 0 | 0 | 0 | 0 | 0 | Good |
| 0 | 0 | 0 | 0 | 0 | 0 | 1 | 0 | Check condition |
| 0 | 0 | 0 | 0 | 0 | 1 | 0 | 0 | Condition met |
| 0 | 0 | 0 | 0 | 1 | 0 | 0 | 0 | Busy |
| 0 | 0 | 0 | 1 | 0 | 0 | 0 | 0 | Intermediate |
| 0 | 0 | 0 | 1 | 0 | 1 | 0 | 0 | Intermediate-condition met |
| 0 | 0 | 0 | 1 | 1 | 0 | 0 | 0 | Reservation conflict |
| 0 | 0 | 1 | 0 | 0 | 0 | 1 | 0 | Command terminated |
| 0 | 0 | 1 | 0 | 1 | 0 | 0 | 0 | Queue full |
| *All other codes are reserved | | | | | | | | |

The Request Sense command

The Request Sense command (03H) requests that the target transfer sense data to the initiator. This data is returned in the extended sense format. Within this format are the following three levels of information:

- Sense key—defined in Table 12.
- Additional Sense Code—see byte 12 listing in Table 13.
- Additional Sense Code qualifiers—see byte 13 listing in Table 13. These qualifiers differentiate between related definitions all having the same Additional Sense Code.

All codes not shown in Table 13 are reserved.

Table 12. Sense key descriptions

| Sense Key | Description |
|------------------|--------------------|
| 0 _H | No sense |
| 1 _H | Recovered error |
| 2 _H | Not ready |
| 3 _H | Medium error |
| 4 _H | Hardware error |
| 5 _H | Illegal request |
| 6 _H | Unit attention |
| 7 _H | Data protect |
| 8 _H | Reserved |
| 9 _H | Reserved |
| A _H | Reserved |
| B _H | Aborted command |
| C _H | Reserved |
| D _H | Reserved |
| E _H | Miscompare |
| F _H | Reserved |

Table 13. Additional sense codes and their qualifiers

| Byte 12 | Byte 13 | Description |
|----------------|----------------|--|
| 00 | 00 | No additional sense information |
| 01 | 00 | No index/sector signal |
| 02 | 00 | No seek complete |
| 03 | 00 | Peripheral device write fault |
| 04 | 00 | Logical unit not ready—cause not reportable |
| 04 | 01 | Logical unit is in process of becoming ready |
| 04 | 02 | Logical unit not ready—initializing command required |
| 04 | 03 | Logical unit not ready—mutual intervention required |
| 04 | 04 | Logical unit not ready—format in progress |
| 05 | 00 | Logical unit does not respond to selection |
| 06 | 00 | No reference position found (track zero or equivalent) |
| 08 | 00 | Logical unit communication failure |
| 08 | 01 | Logical unit communication time-out |
| 08 | 02 | Logical unit communication parity error |
| 09 | 00 | Track-following error |
| 0A | 00 | Error log overflow |
| 0C | 01 | Write error recovered with auto reallocation |
| 0C | 02 | Write error—auto reallocation failed |
| 10 | 00 | ID CRC or ECC error |
| 11 | 00 | Unrecovered read error |
| 11 | 01 | Read retries exhausted |
| 11 | 02 | Error too long to correct |
| 11 | 03 | Multiple read errors |
| 11 | 04 | Unrecovered read error—auto reallocate failed |
| 11 | 0A | Miscorrected error |
| 12 | 00 | Address mark not found for ID field |
| 13 | 00 | Address mark not found for data field |
| 14 | 00 | Recorded entity not found |
| 14 | 01 | Record not found |
| 15 | 00 | Random positioning error |
| 15 | 01 | Mechanical positioning error |
| 15 | 02 | Positioning error detected by read of medium |
| 16 | 00 | Data synchronization mark error |
| 17 | 00 | Recovered data with no error correction applied |
| 17 | 01 | Recovered data with retries |

continued

continued from previous page

| Byte 12 | Byte 13 | Description |
|----------------|----------------|---|
| 17 | 02 | Recovered data with positive head offset |
| 17 | 03 | Recovered data with negative head offset |
| 17 | 05 | Recovered data with previous sector ID |
| 17 | 06 | Recovered data without ECC—data auto-reallocated |
| 18 | 00 | Recovered data with error correction applied |
| 18 | 01 | Recovered data with error correction and retries applied |
| 18 | 02 | Recovered data with ECC and/or retries—data auto-reallocated |
| 19 | 00 | Defect list error |
| 19 | 01 | Defect list not available |
| 19 | 02 | Defect list error in primary list |
| 19 | 03 | Defect list error in grown list |
| 1A | 00 | Parameter list length error |
| 1B | 00 | Synchronous data transfer error |
| 1C | 00 | Defect list not found |
| 1C | 01 | Primary defect list not found |
| 1C | 02 | Grown defect list not found |
| 1D | 00 | Miscompare during verify operation |
| 1E | 00 | Recovered ID with ECC correction |
| 20 | 00 | Invalid command operation code |
| 21 | 00 | Logical block address out of range |
| 24 | 00 | Invalid field in CDB—check field pointer in sense data |
| 25 | 00 | Logical unit not supported |
| 26 | 00 | Invalid field in parameter list—check field pointer in sense data |
| 26 | 01 | Parameter not supported—check field pointer in sense data |
| 26 | 02 | Parameter value invalid—check field pointer in sense data |
| 26 | 03 | Threshold parameters not supported |
| 27 | 00 | Write protected |
| 28 | 00 | Not ready to ready transition—medium may have changed |
| 29 | 00 | Power on, reset, or bus device reset occurred |
| 29 | 00 | Device reset message, bus reset (dual port only) |
| 29 | 01 | Power on, reset (dual port only) |
| 2A | 00 | Parameters changed |
| 2A | 01 | Mode parameters changed |
| 2A | 02 | Log parameters changed |
| 2B | 00 | Copy cannot execute since host cannot disconnect |
| 2C | 00 | Command sequence error |

continued

continued from previous page

| Byte 12 | Byte 13 | Description |
|----------------|----------------|---|
| 2F | 00 | Commands cleared by another initiator |
| 30 | 01 | Cannot read medium—unknown format |
| 30 | 02 | Cannot read medium—incompatible format |
| 31 | 00 | Medium format corrupted |
| 31 | 01 | Format command failed |
| 32 | 00 | No defect spare location available |
| 32 | 01 | Defect list update failure |
| 37 | 00 | Rounded parameter |
| 39 | 00 | Saving parameters not supported |
| 3A | 00 | Medium not present |
| 3D | 00 | Invalid bits in identify message |
| 3E | 00 | Logical unit has not self-configured yet |
| 3F | 00 | Target operating conditions have changed |
| 3F | 01 | Microcode has been changed |
| 3F | 02 | Changed operating definition |
| 3F | 03 | Inquiry data has changed |
| 40 | NN | Diagnostic failure—more description in ASCQ (Byte 13 codes 80H–FFH) |
| 40 | 00 | RAM failure (should use 40 NN) |
| 41 | 00 | Data path failure (should use 40 NN) |
| 42 | 00 | Power on or self-test failure (should use 40 NN) |
| 43 | 00 | Message error |
| 44 | 00 | Internal target failure |
| 45 | 00 | Select/reselect failure |
| 46 | 00 | Unsuccessful soft reset |
| 47 | 00 | SCSI parity error |
| 48 | 00 | Initiator detected error message received |
| 49 | 00 | Invalid message error |
| 4A | 00 | Command phase error |
| 4B | 00 | Data phase error |
| 4C | 00 | Logical unit failed self-configuration |
| 4E | 00 | Overlapped commands attempted |
| 53 | 02 | Medium removal prevented |
| 5A | 00 | Operator request or state change input (unspecified) |
| 5A | 01 | Operator medium removal request |
| 5A | 02 | Operator selected write protect |

continued

continued from previous page

| Byte 12 | Byte 13 | Description |
|---------|---------|--|
| 5A | 03 | Operator selected write permit |
| 5B | 00 | Log exception |
| 5B | 01 | Threshold condition met |
| 5B | 02 | Log counter at maximum |
| 5B | 03 | Log list codes exhausted |
| 5C | 00 | RPL status change |
| 5C | 01 | Spindles synchronized |
| 5C | 02 | Spindles not synchronized |
| XX | | Additional Sense Codes in the range of 80H–FFH are vendor unique |
| | XX | Additional Sense Code Qualifiers in the range of 80H–FFH are vendor unique |

The Receive Diagnostic Results command

The Receive Diagnostic Results command (1CH) requests that analysis data be sent to the initiator after completion of a Send Diagnostic command. The results of power on initialization tests are available through the Request Sense command as well as this command. Diagnostic data return bytes are shown in Table 14.

Table 14. Diagnostic data return bytes

| Byte | Description |
|------|---|
| 0 | Additional length (bit 7 = most significant bit) |
| 1 | Additional length (bit 0 = least significant bit) |
| 2 | FRU code (most probable) |
| 3 | FRU code |
| 4 | FRU code |
| 5 | FRU code (least probable) |
| 6 | Error code (bit 7 = most significant bit) |
| 7 | Error code (bit 0 = least significant bit) |

Additional length field

This two-byte field indicates the number of additional bytes included in the diagnostic data list. This value will always be 0006H. This means there are six additional bytes (bytes 2–7).

Field replaceable unit (FRU) code

In the event of a failure, the FRU code byte identifies the assembly that may have failed. The codes are listed in probability order with the most probable assembly listed first and the least probable listed last. FRU codes are shown in Table 15.

Table 15. SCSI online FRU codes

| Code | Description |
|-------------|---------------------------|
| 00H | No information or unknown |
| 01H | Replace entire drive |
| 02H | Undefined |
| 03H | Undefined |

Error code

This two-byte value provides information about what part of the diagnostic operation has failed. The error codes are shown in Table 16.

Table 16. Error codes

| Code | Description |
|-------------|---|
| 0001H | Formatter diagnostic error |
| 0002H | Microprocessor RAM diagnostic error |
| 0004H | No drive ready |
| 0008H | No sector or index detected |
| 0009H | Fatal hardware error while doing drive diagnostics |
| 000CH | No drive command complete |
| 0010H | Unable to set drive sector size |
| 0014H | Unable to clear drive attention |
| 0018H | Unable to start spindle motor |
| 0020H | Unable to recalibrate drive |
| 0030H | Unable to send write current data to drive |
| 0034H | Unable to issue drive seek command |
| 0040H | Unable to read user table from drive |
| 0041H | Ran out of sectors while doing drive diagnostics |
| 0042H | Unable to read reallocation table |
| 0043H | Unable to read ETF log |
| 0044H | Unable to read firmware stored on disc |
| 0045H | Firmware read from disc or sent by host has an invalid checksum |
| 0060H | Thermal calibration failure |
| 0070H | Microprocessor internal timer error |
| 0080H | Buffer controller diagnostic error |
| 0081H | Buffer RAM diagnostic error |
| 00C1H | Data miscompare while doing drive diagnostics |
| 00F0H | PROM checksum error |
| 00F1H | CPU error |
| 00F2H | SCSI protocol chip error |
| 00F3H | ECC subsystem error |



Seagate Technology, Inc.
920 Disc Drive, Scotts Valley, CA 95066-4544, USA

Publication Number: 83327730, Rev. C, Printed in USA